

Übersichtszeichnung Seitenansicht:

Spannweite: ca. 770 mm
Rumpflänge: ca. 880 mm
Fluggewicht: ca. 500 - 550 Gramm
Antrieb: Außenläufer 2830 ca. 150 Watt
Flugregler: 30- 40 Ampere mit BEC
Antriebsakku: 3S/1300 bis 1800mAh Lipo
Schwerpunkt: 150-153 mm ab Tragflächenvorderkante
Luftschraube: 7x7 APC E-Prop oder ähnliche

Runderausströme
Querruder: ± 15 mm
Höhenruder: ± 11 mm

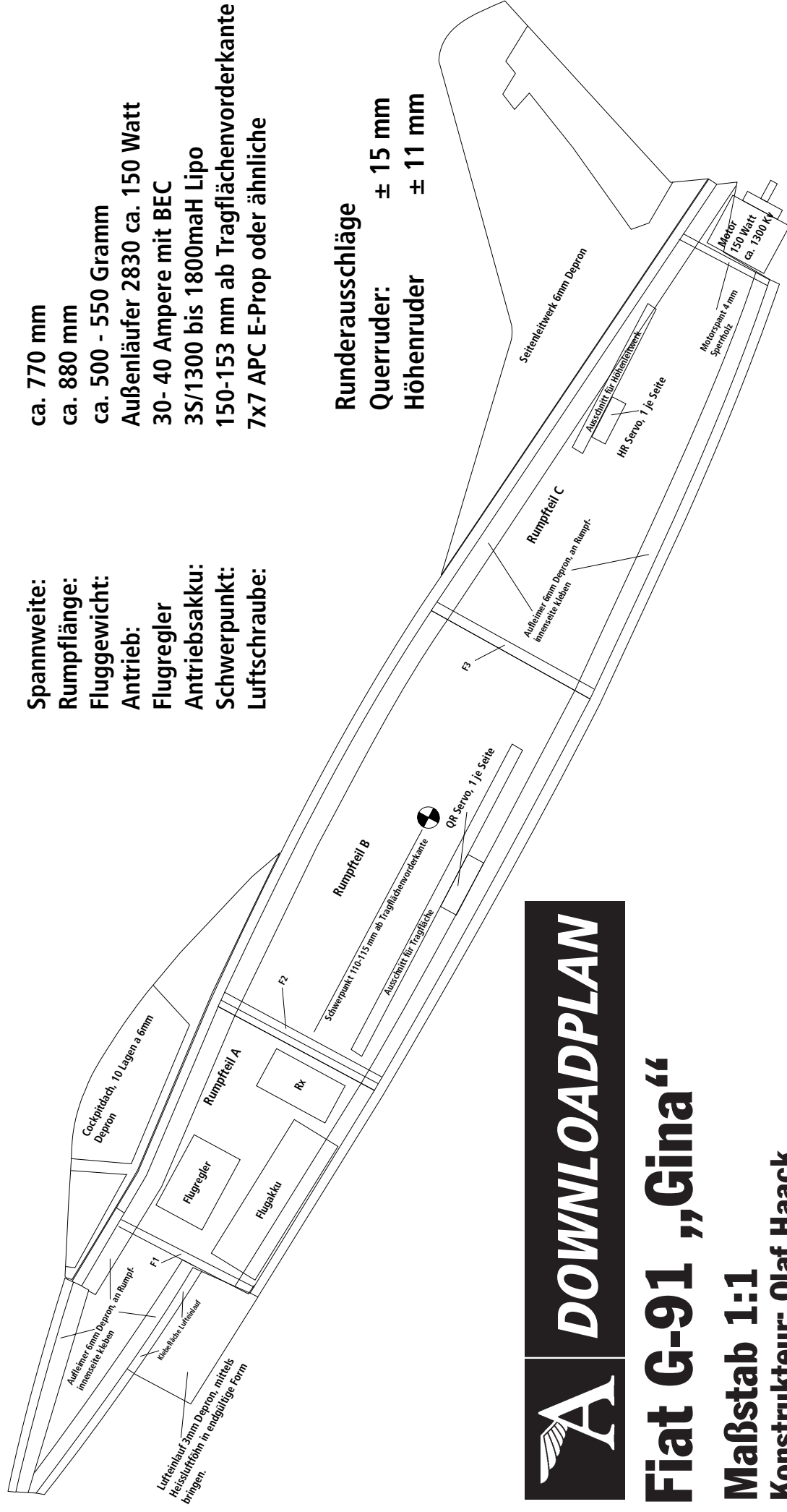

A DOWNLOADPLAN

Fiat G-91 „Gina“

Maßstab 1:1

Konstrukteur: Olaf Haack

© 2016 Modell AVIATOR

Modell AVIATOR-Downloadpläne sind Bestandteil des Magazins und nur für private Zwecke zu nutzen. Für die gewerbliche Herstellung der Bauplanmodelle oder von Teilen davon ist eine Genehmigung durch den Verlag Wellhausen & Marquardt Medien erforderlich.

Achtung: Beim drucken Seitenanpassung: keine.

Alle Teile, sofern nicht anders angegeben, aus 6mm Depron anfertigen

Übersichtzeichnung Draufsicht
nur schematische Darstellung,
nicht maßstabgetreu!

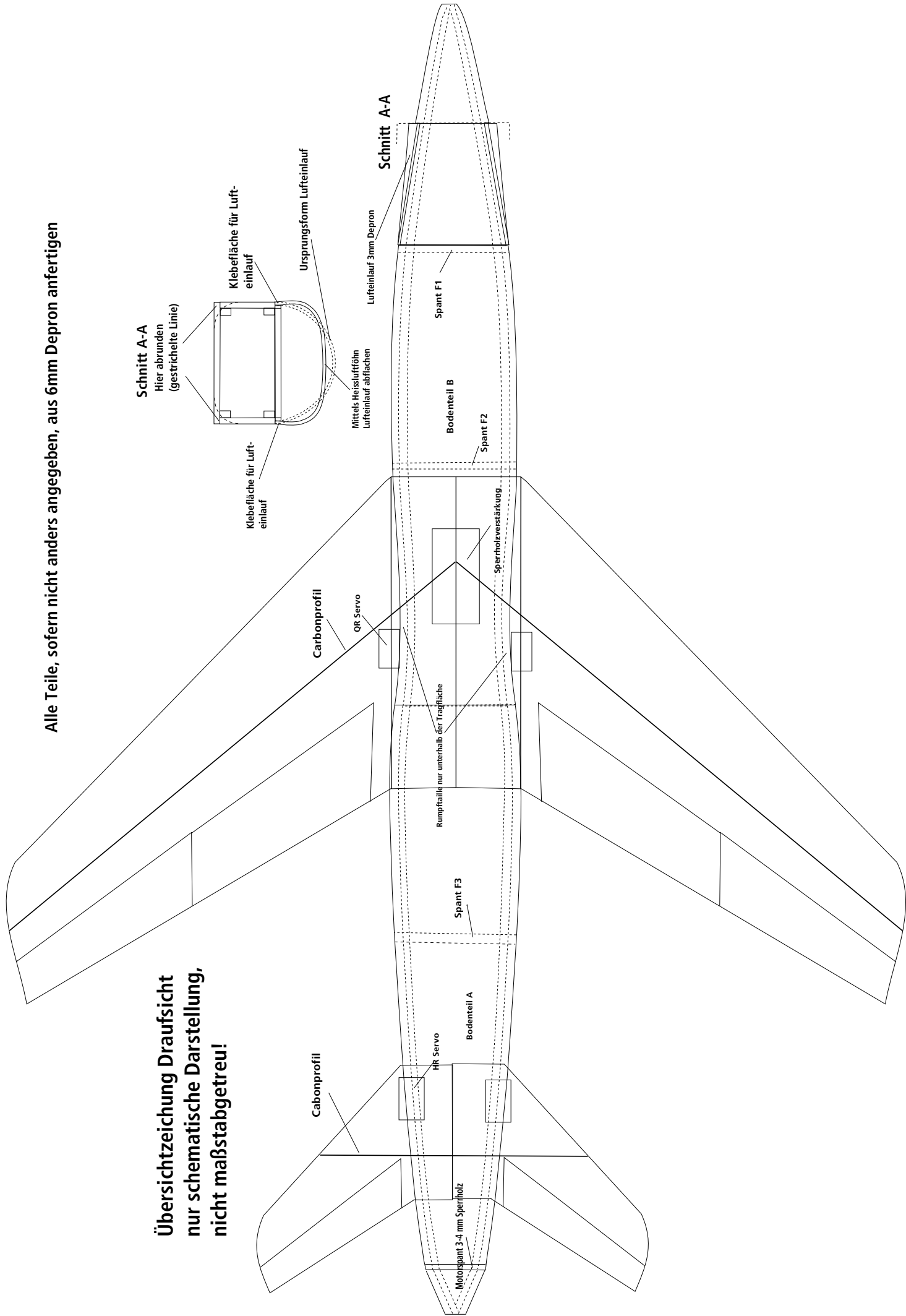

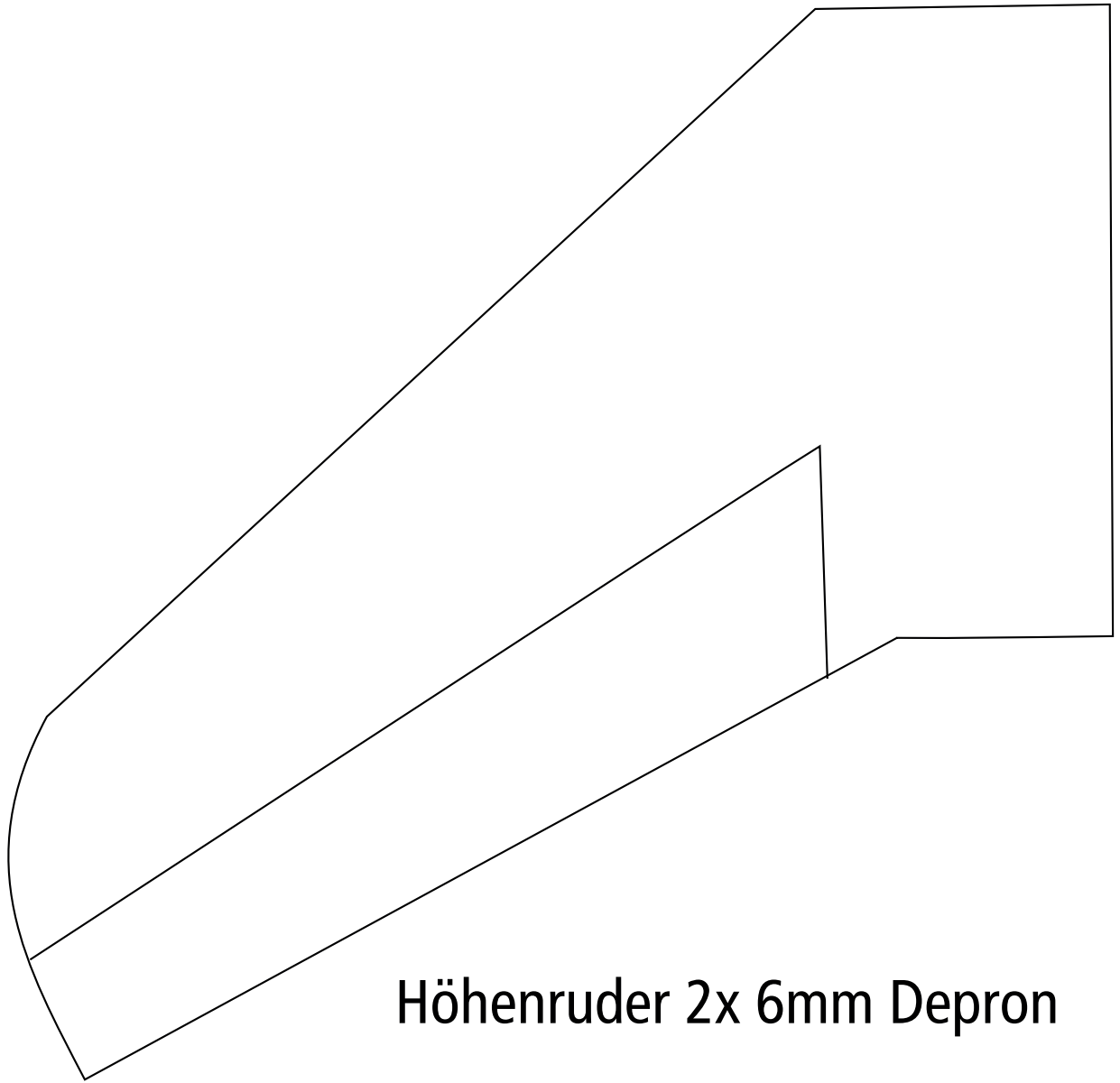

Höhenruder 2x 6mm Depron

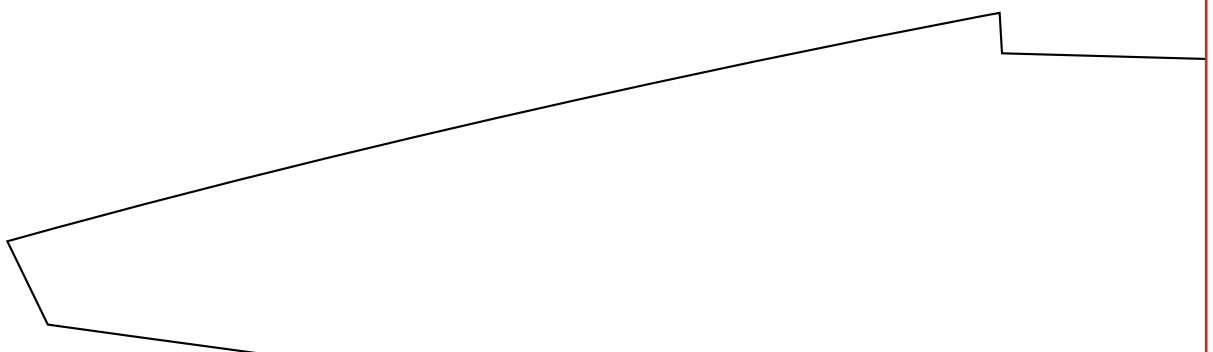

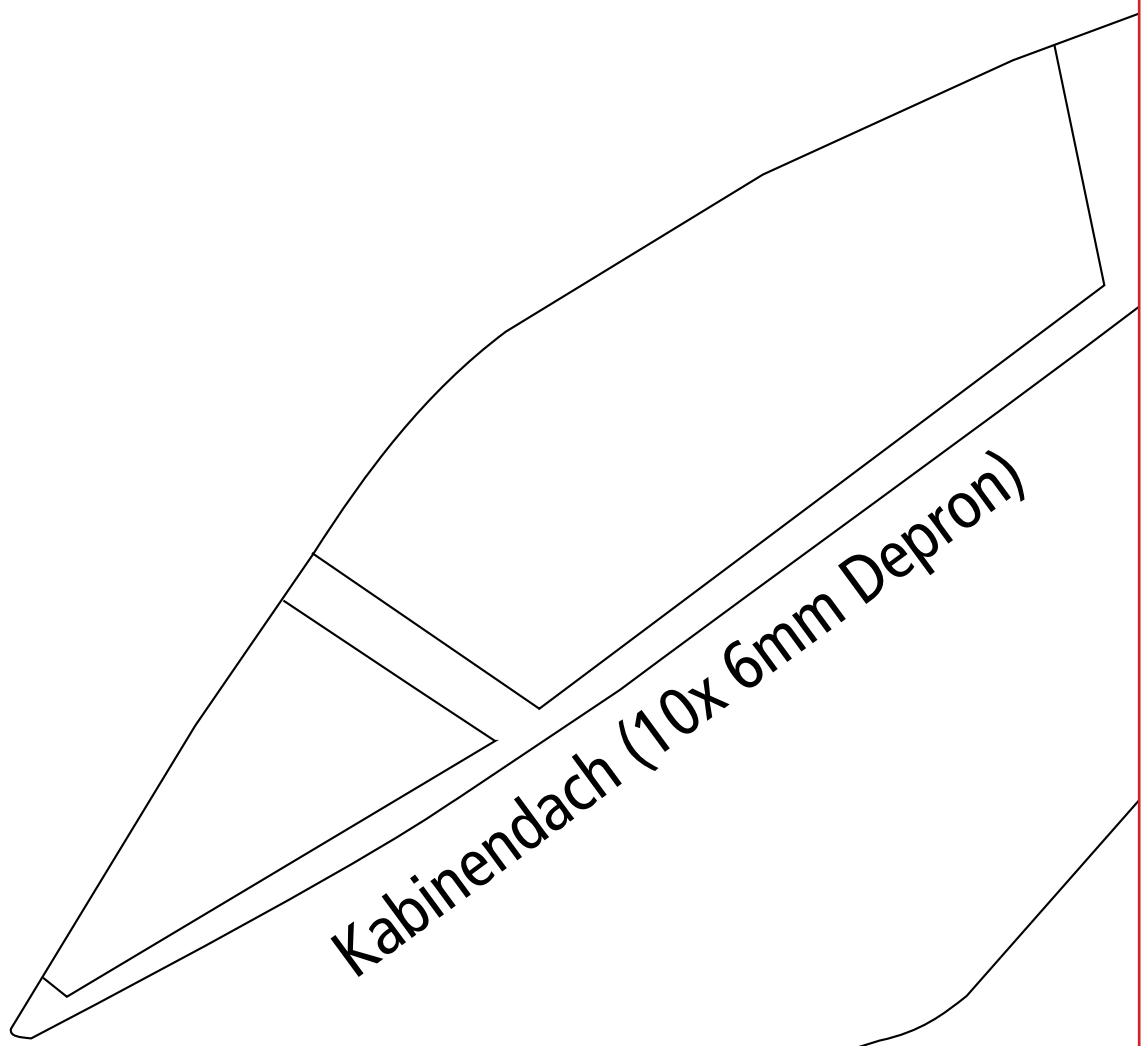

Kabinendach (10x 6mm Depron)

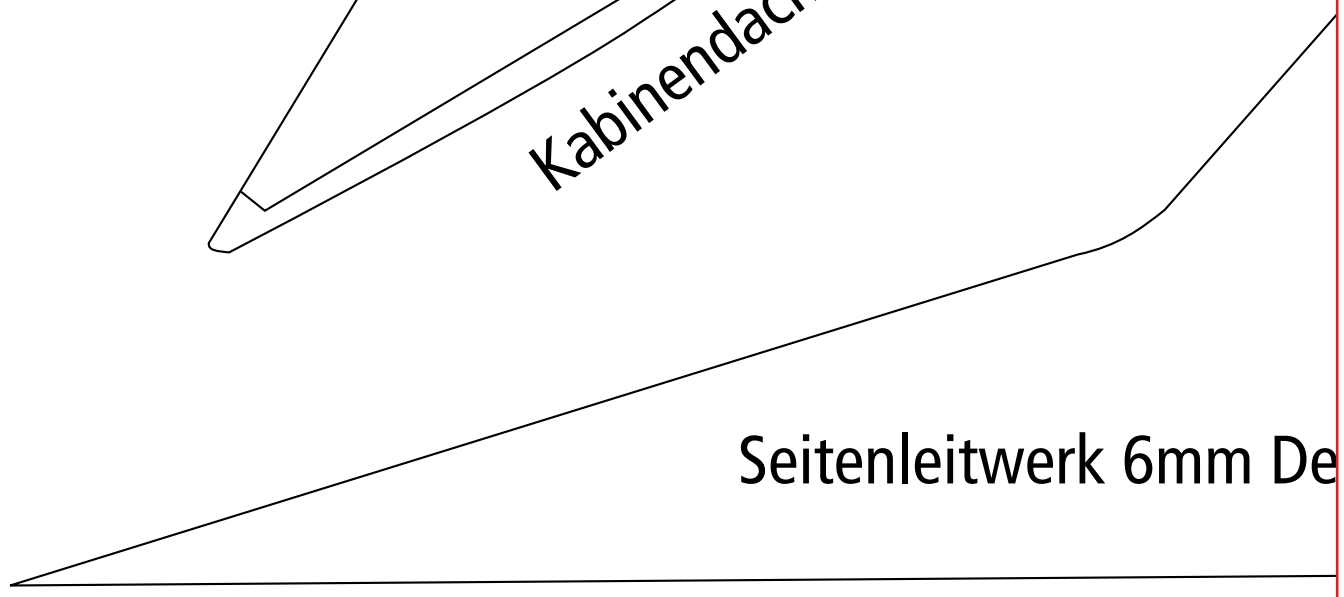

Seitenleitwerk 6mm De

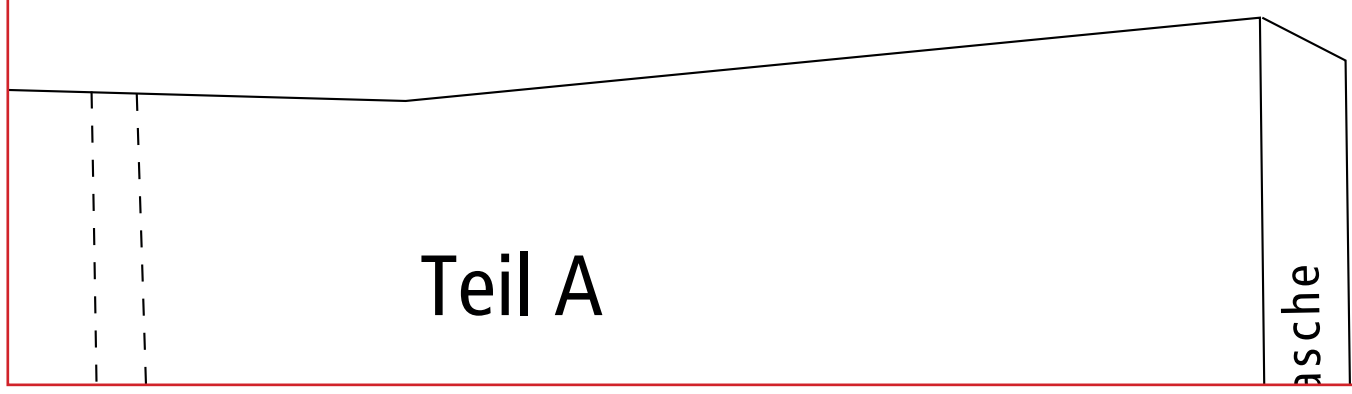

Teil A

asche

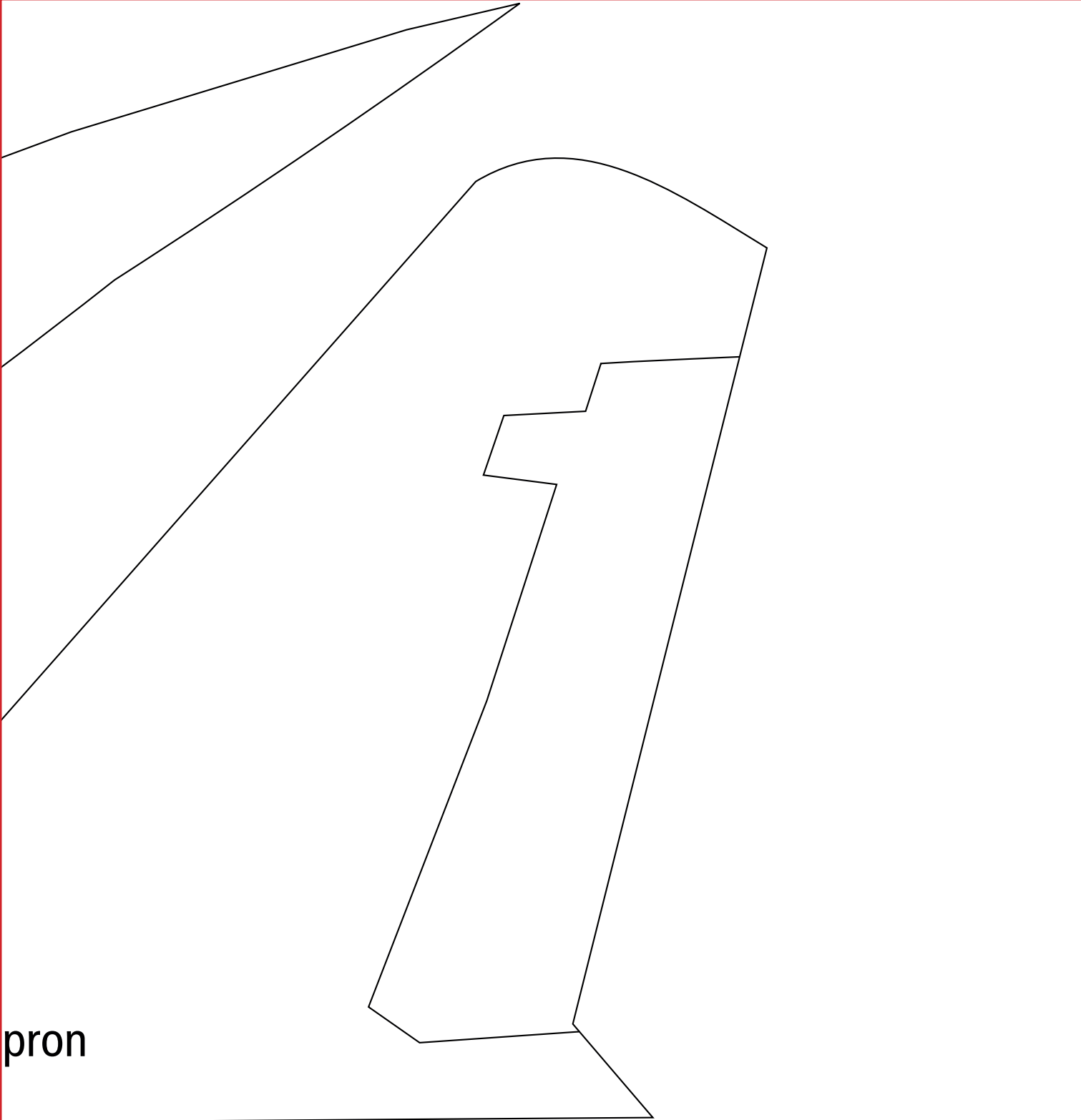

pron

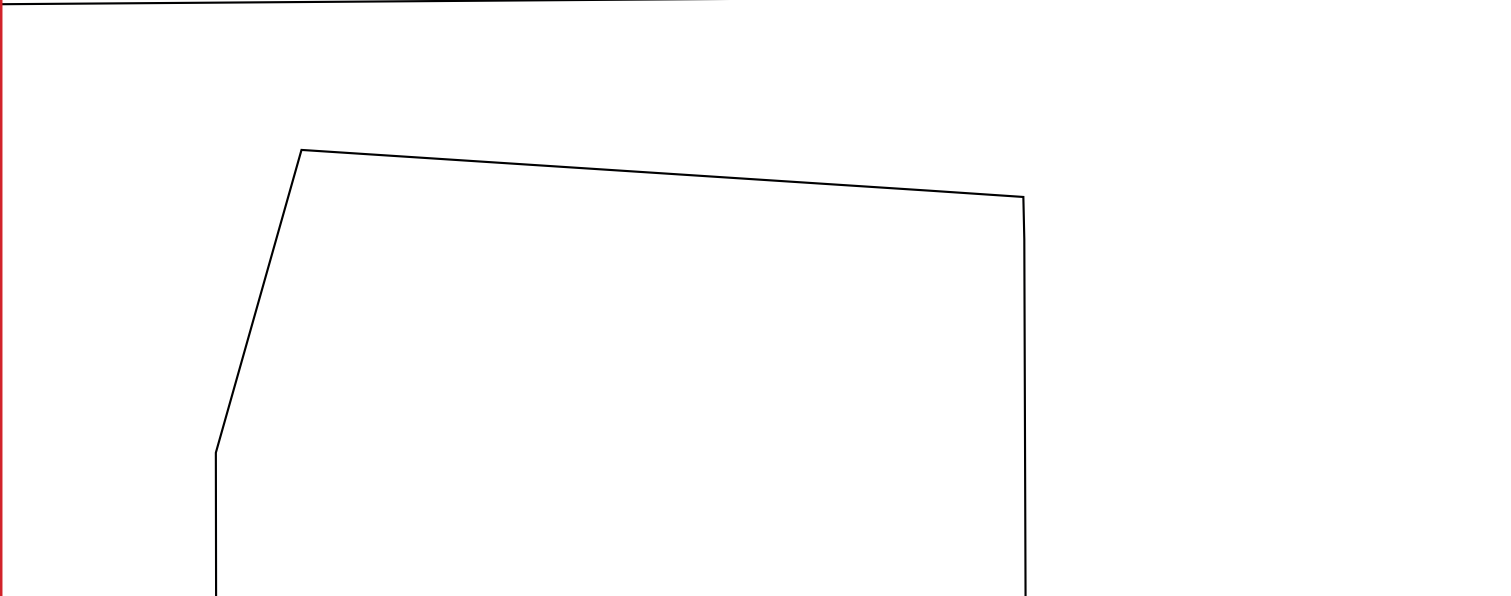

Rumpfseiten, je 2x 6mm Depron



Teil C

The diagram shows a trapezoidal part labeled 'Teil C'. It has a vertical left edge, a shorter vertical right edge, and two slanted top and bottom edges. A dashed vertical line is positioned to the left of the part, extending from the top edge to the bottom edge. A small square symbol is located at the top-right corner of the part.



Teil B

The diagram shows a trapezoidal part labeled 'Teil B'. It has a vertical left edge, a shorter vertical right edge, and two slanted top and bottom edges. A dashed vertical line is positioned to the left of the part, extending from the top edge to the bottom edge.

Klebel

an Rumpfteil B kleben

Rumpfsp

an Rumpfteil C kleben

Klebe lasche

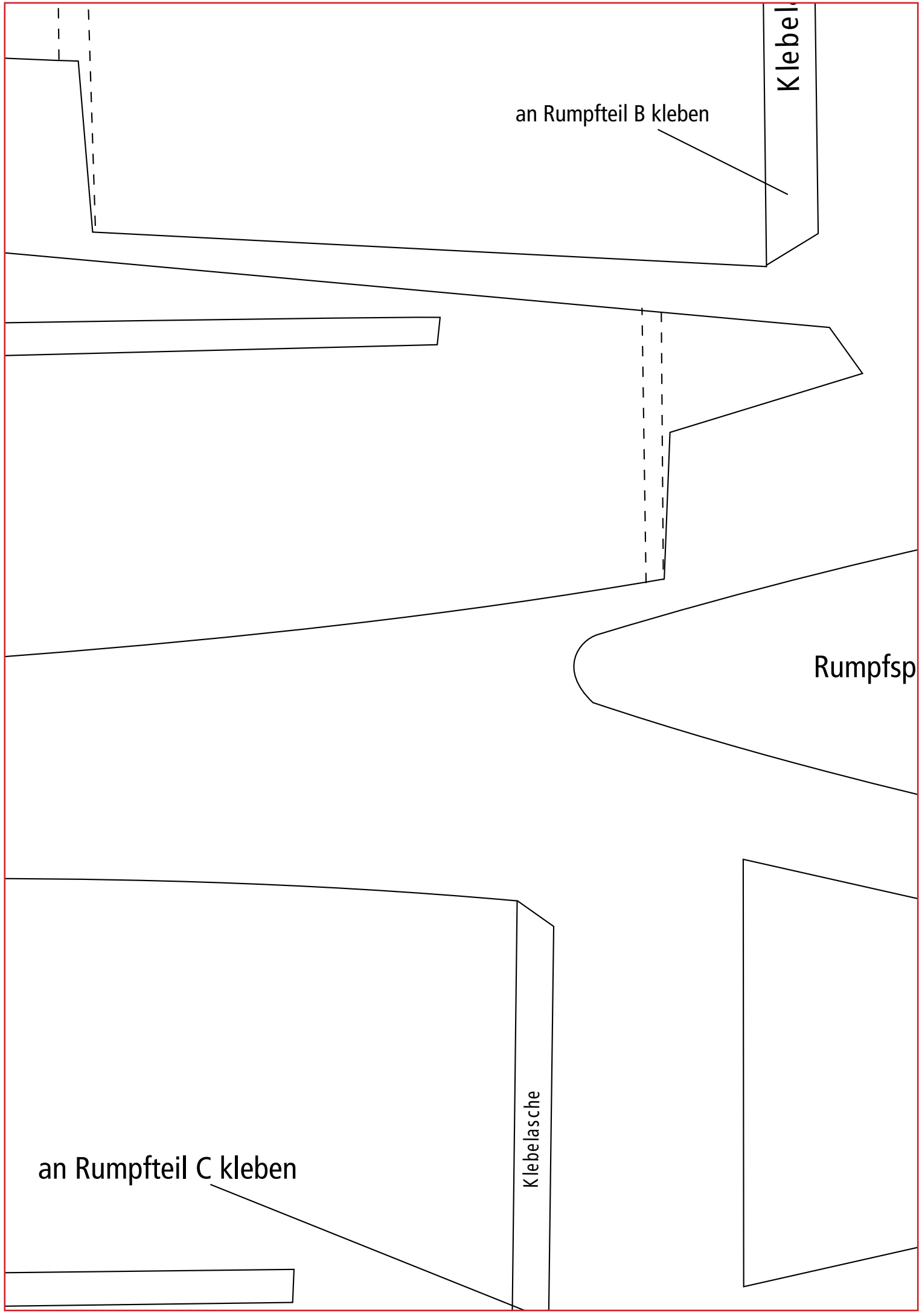

Lufteinlauf, 3 mm Depron

Spitze oben

Hier Bauteil trennen

Rumpfspitze unten

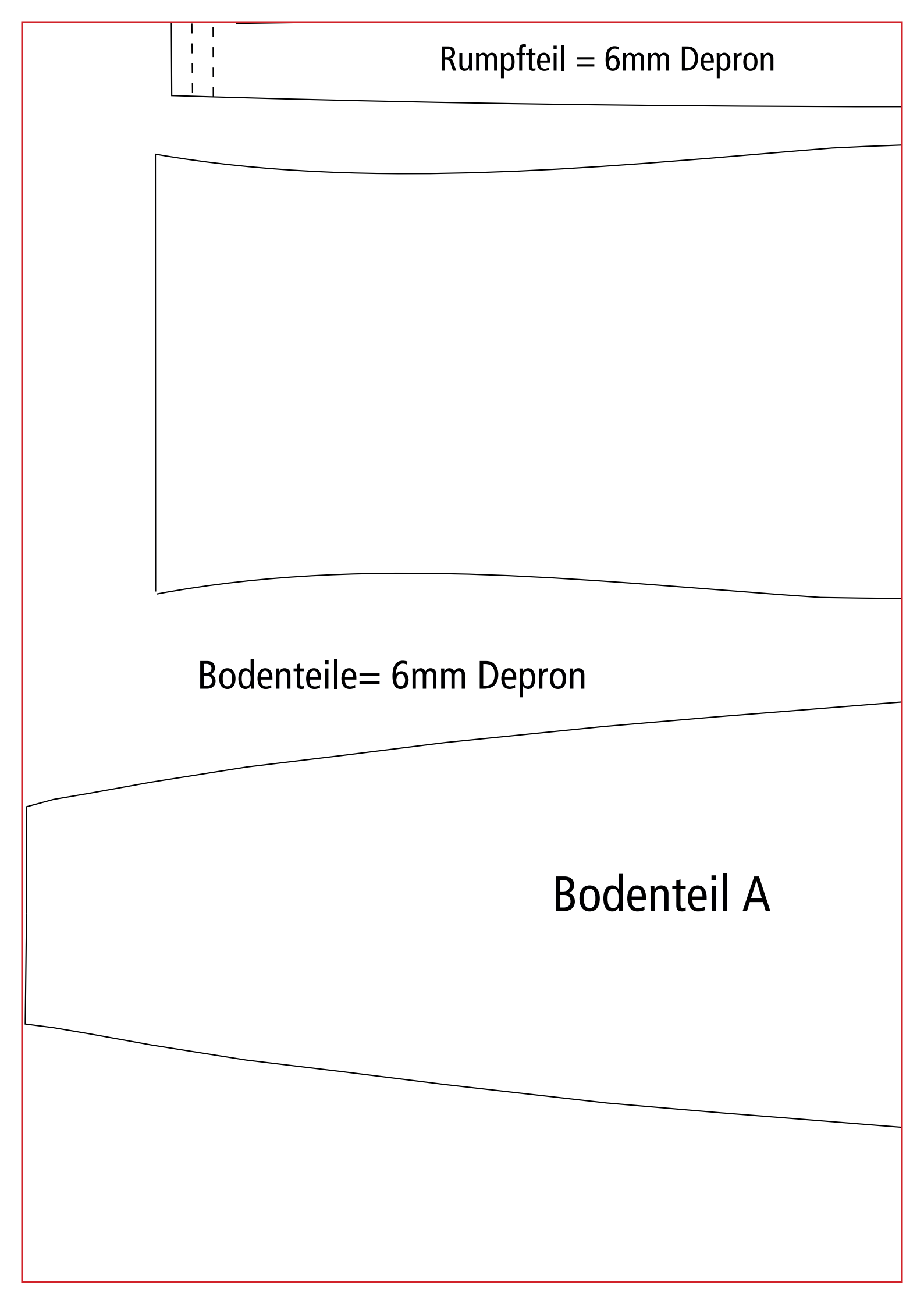

Rumpfteil = 6mm Depron

The diagram shows a technical drawing of a component, likely a model for a robot or a similar device. It is divided into three distinct sections. The top section is a thin, rectangular layer labeled 'Rumpfteil = 6mm Depron'. Below this is a larger, trapezoidal section labeled 'Bodenteile = 6mm Depron'. The bottom section is another trapezoidal section labeled 'Bodenteil A'. The top-left corner of the top section is shown with dashed lines, indicating a hidden edge. The entire drawing is enclosed in a red border.

Bodenteile = 6mm Depron

Bodenteil A

Bodenteil B

Spant F3

an Bodenteil B kleben

Klebelasche

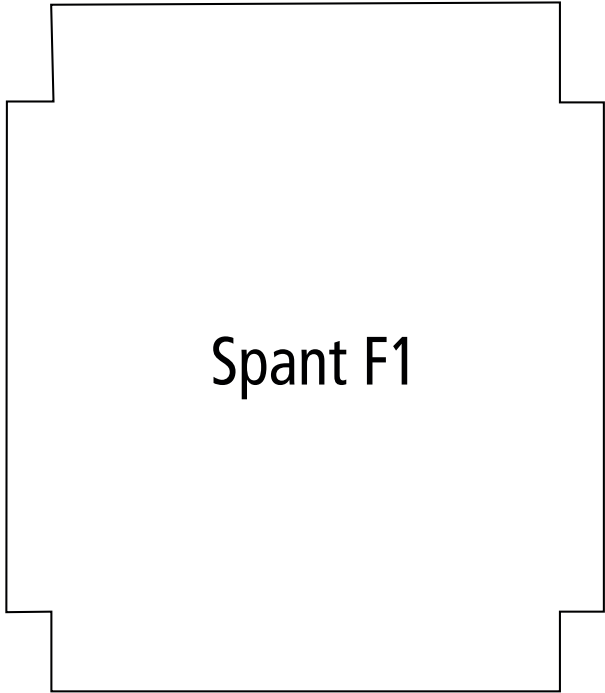
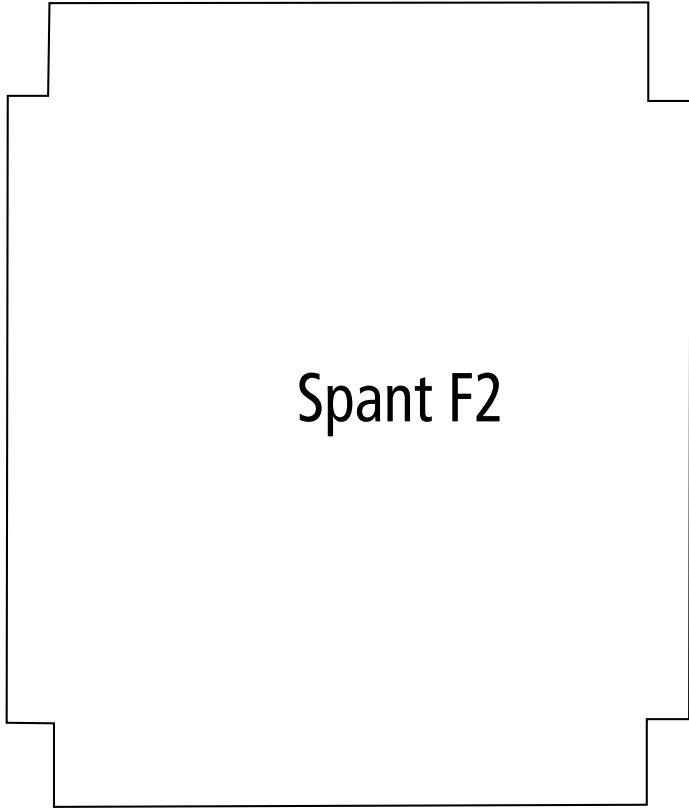
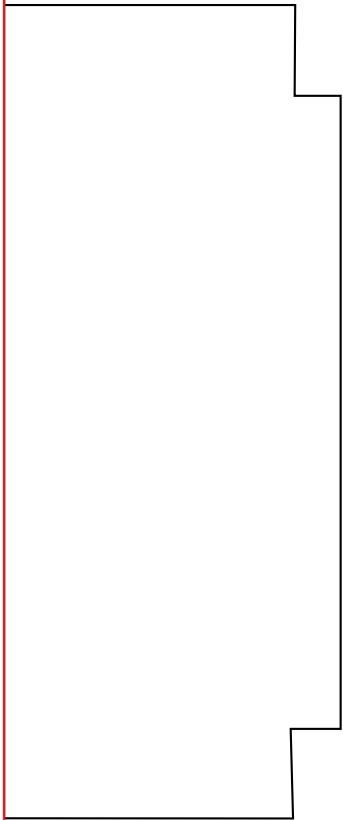

Spanten = 6mm Depron

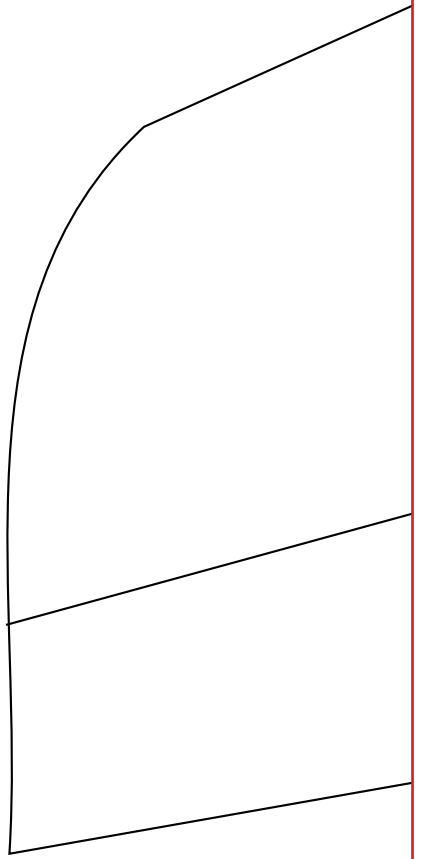
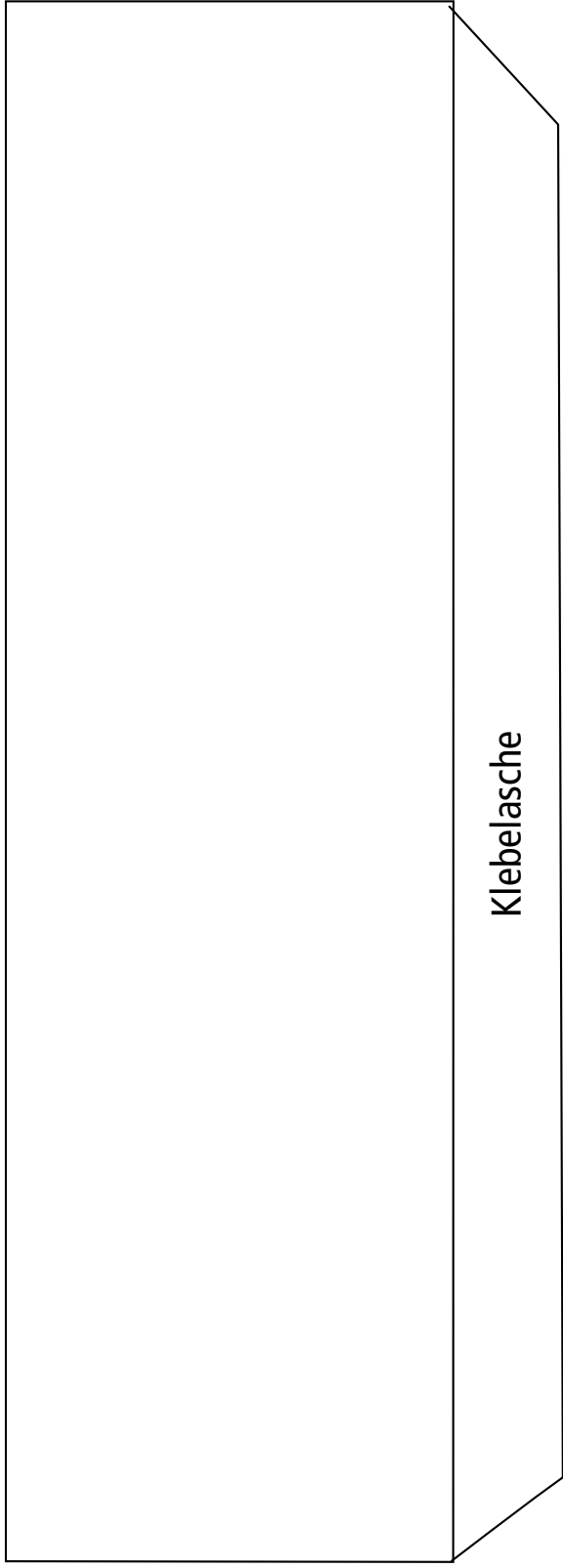

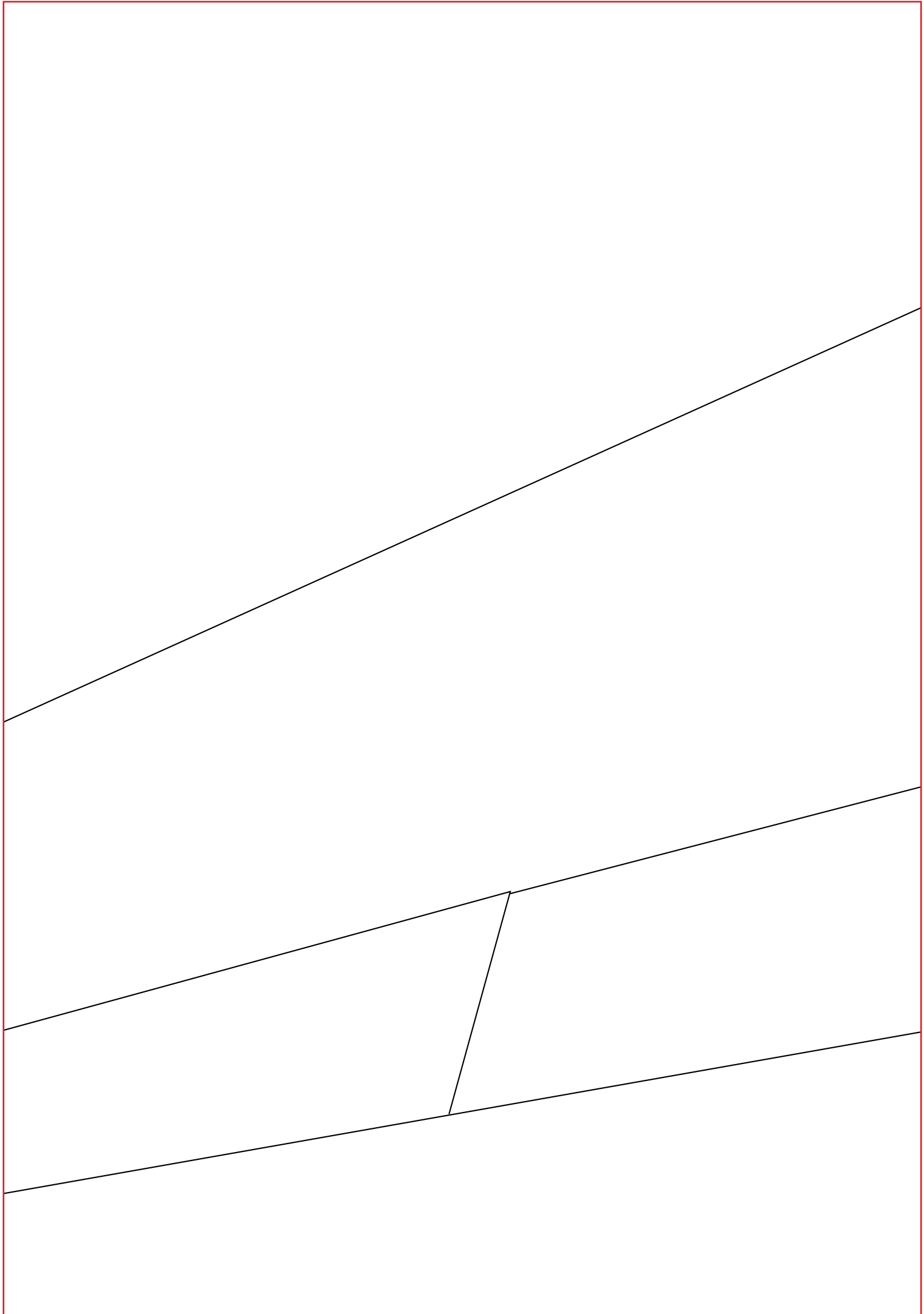

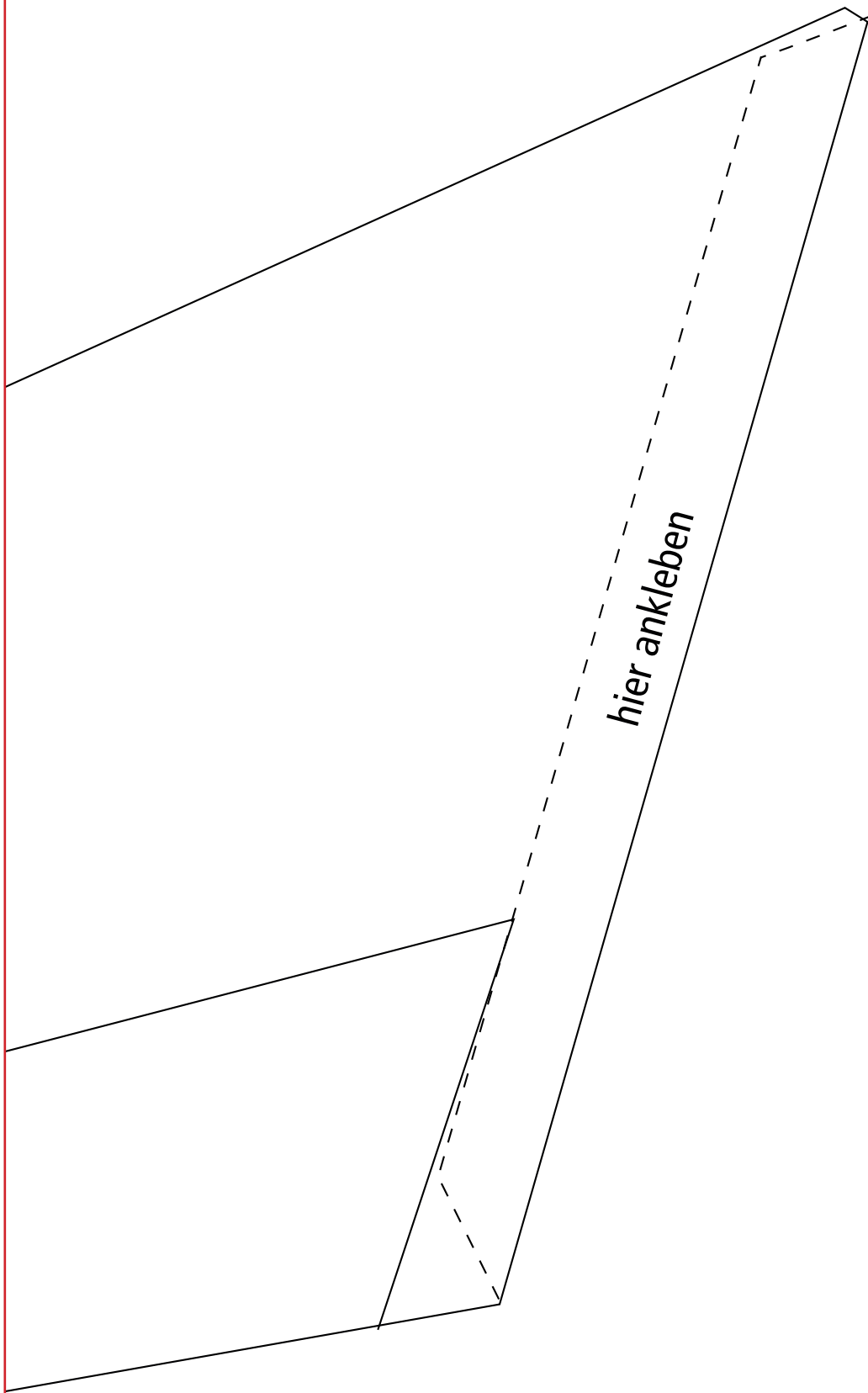

Tragfläche 6mm Depron (2x)

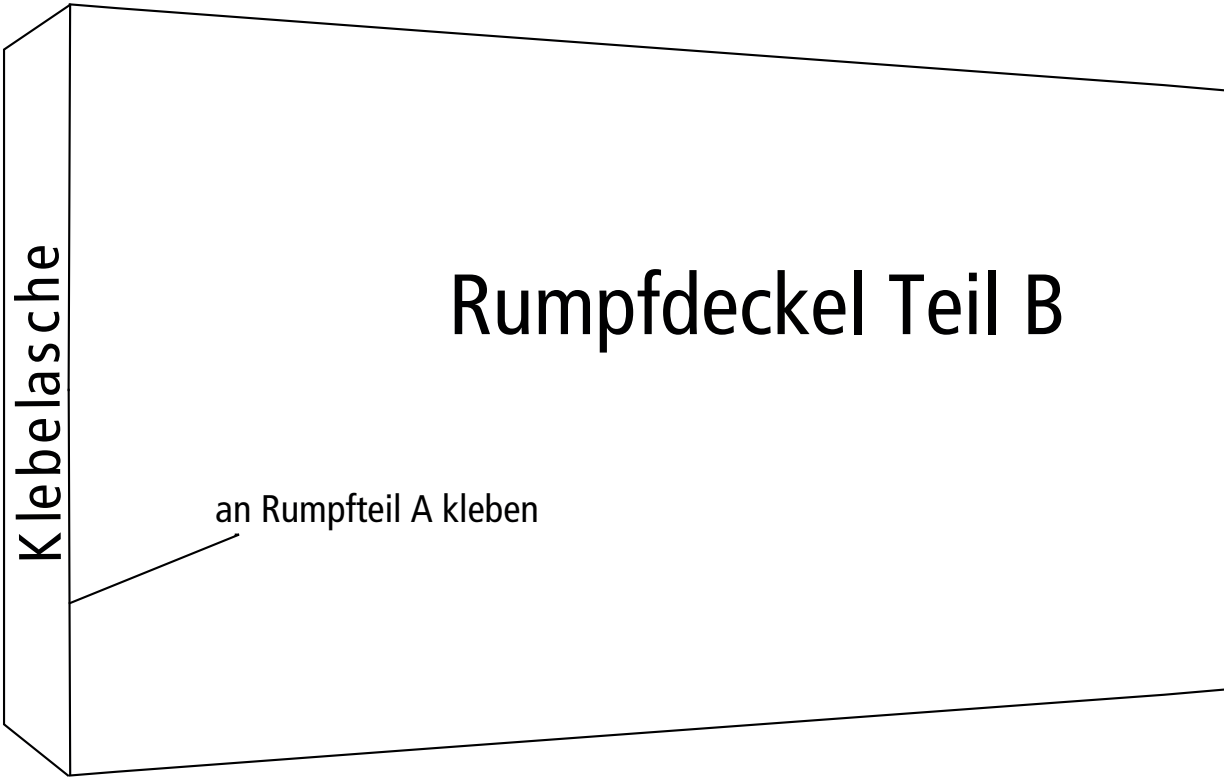
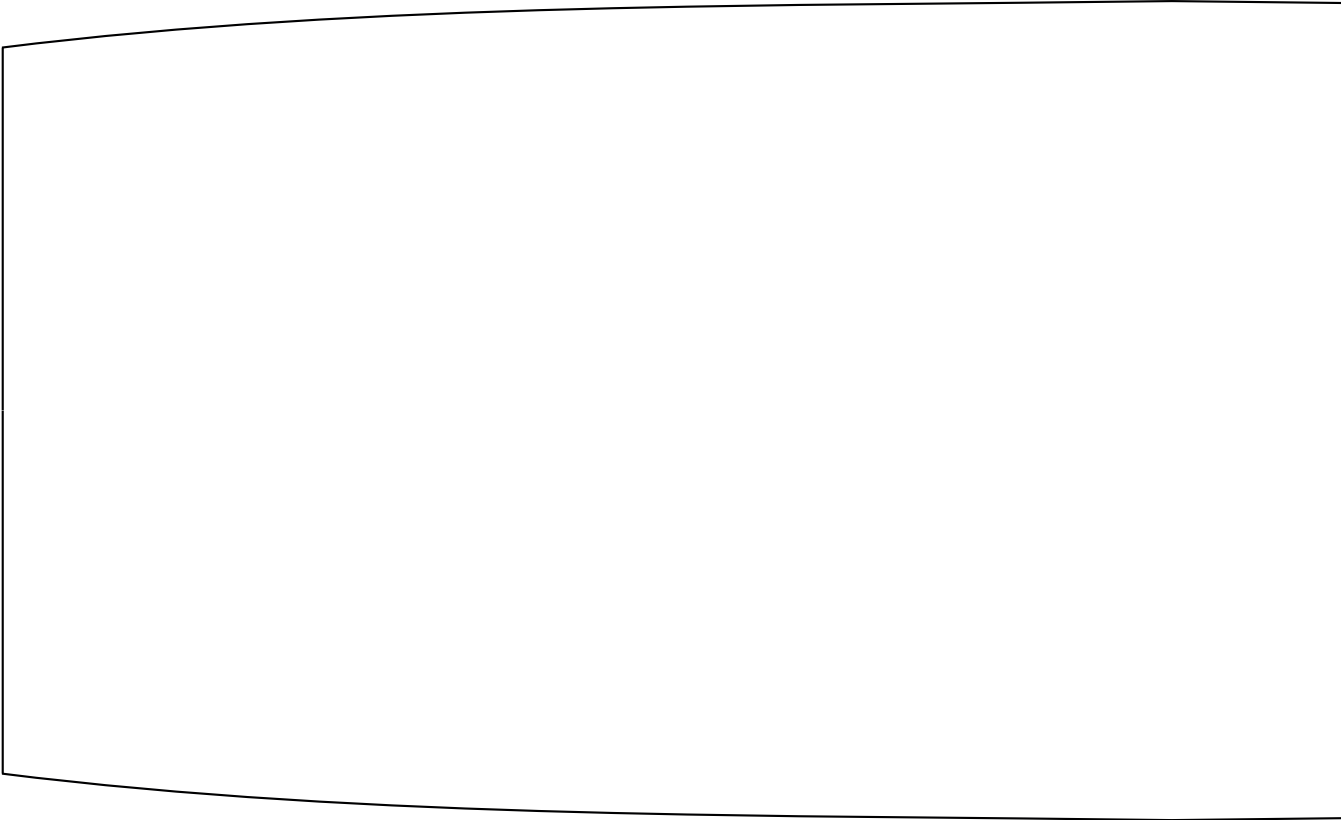

Klebelasche

Rumpfdeckel Teil B

an Rumpfteil A kleben

Rumpfdeckel Teil A

an Rumpfteil B
Kleben

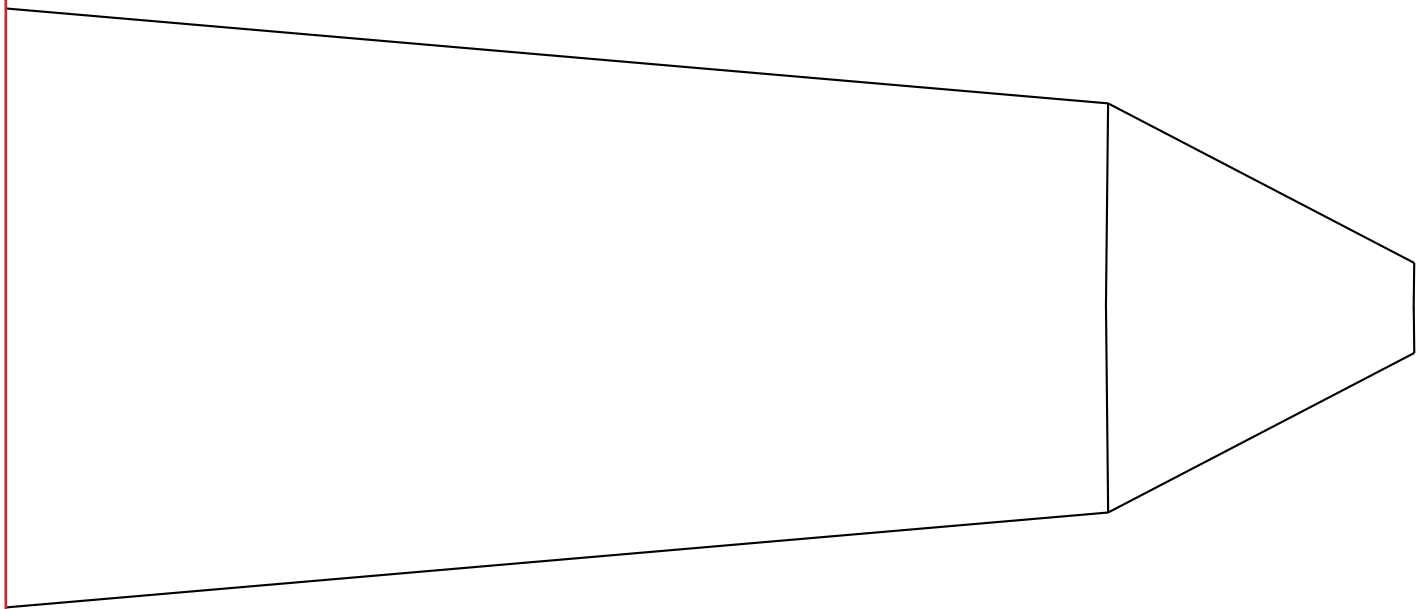

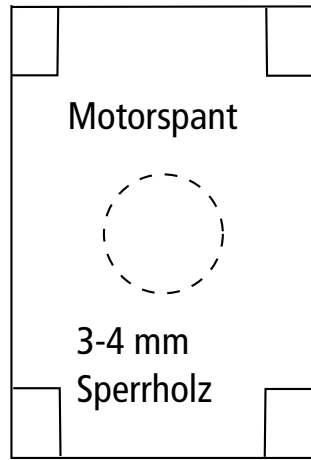
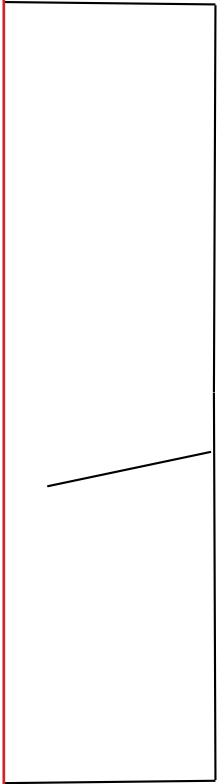

Motorspant

3-4 mm
Sperrholz

3

0

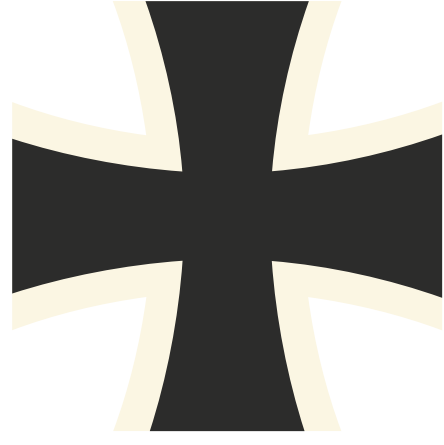

0

7



3

0

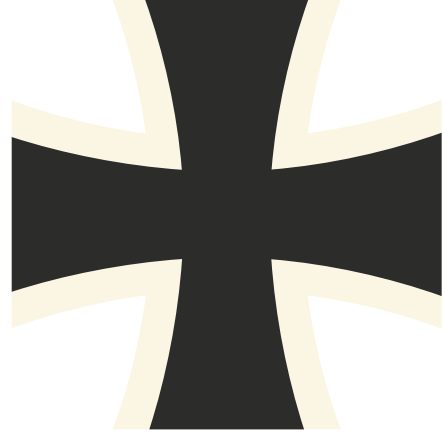

0

7



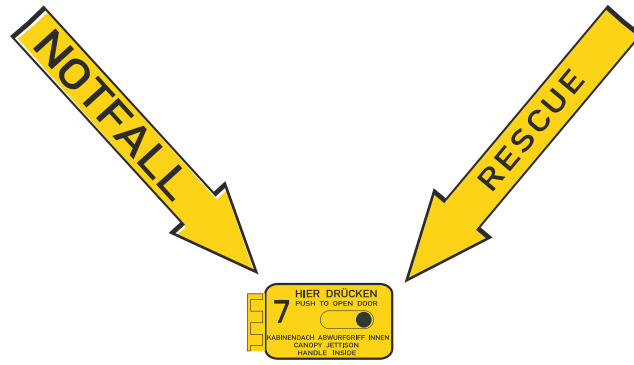
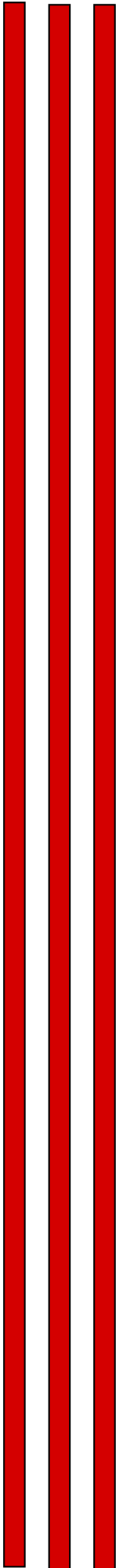

NOTFALL
RELEASE T-HANDLE
TO JETTISON CANOPY
RESCUE

Fiat G-91
www.modell-aviator.de
Antrieb: 2830 AL
Akku: 3S- 1300
2015

DANGER
KEEP WELL AWAY
FROM INTAKE WHILE
ENGINES ARE RUNNING

DANGER
KEEP WELL AWAY
FROM INTAKE WHILE
ENGINES ARE RUNNING